

**REF. 2.014**

**F1291 Mesa de Centro**

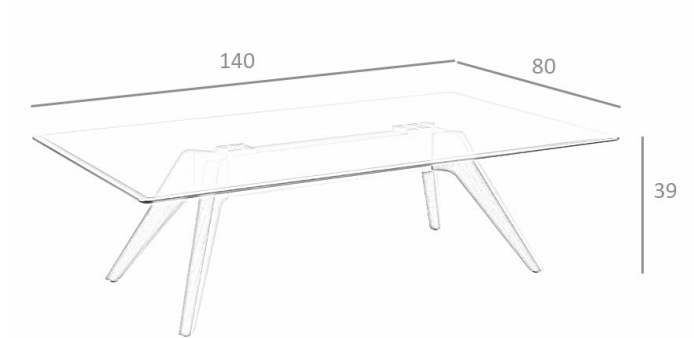

### **MEDIDAS**

Medidas: 140 x 80 x 39 cm.

Peso: 38 Kg.

Forma: Rectangular

### **EMBALAJE**

147 x 88 x 65 cm. / 34 Kg.

77 x 10 x 12 cm. / 6 Kg.

66 x 19 x 13 cm. / 4 Kg.

### **VOLUMEN**

0,24 m<sup>3</sup>

### **PRODUCTO**

Chapa Nogal / Acero Pulido

Tapa: Cristal-TTE

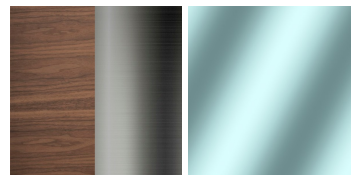

### **PATAS**

Material Patas: Chapa Nogal

