

**REF. 2.060**

**MH1316A Mesa de Centro**

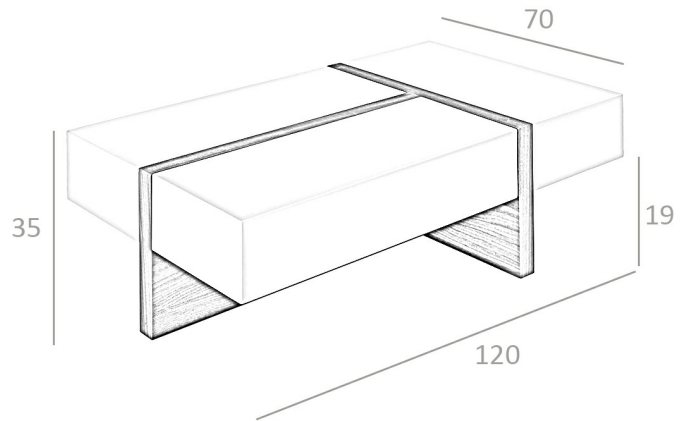

**MEDIDAS**

Medidas: 120 x 70 x 35 cm.

Peso: 29 Kg.

**EMBALAJE**

125 x 75 x 40 cm. / 31 Kg.

**VOLUMEN**

0,41 m<sup>3</sup>

**PRODUCTO**

Chapa Nogal / DM Lacado  
Blanco Similar 9003 - Brillo

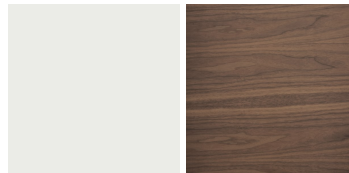

**PATAS**

Material Patas: Madera color Nogal

