

**REF. 2.095**

**GOB-N5430-0 Mesa de Rincón**

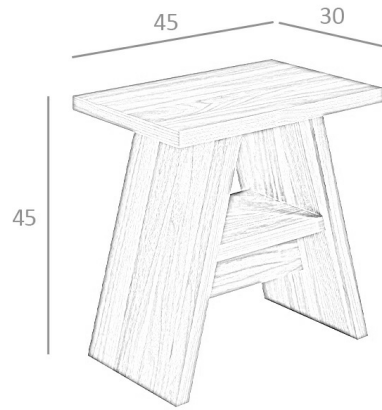

**MEDIDAS**

Medidas: 45 x 30 x 45 cm.

Peso: 9 Kg.

**EMBALAJE**

47 x 32 x 47 cm. / 11 Kg.

**VOLUMEN**

0,06 m3

**PRODUCTO**

Chapa Nogal

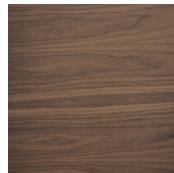

**PATAS**