

REF. 3.024

GOB-N5405 / CPM5612 Estantería

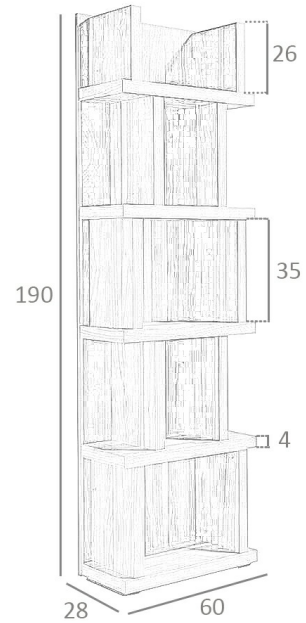

MEDIDAS

Medidas: 60 x 28 x 190 cm.

Peso: 45 Kg.

EMBALAJE

63 x 31 x 193 cm. / 47 Kg.

VOLUMEN

0,35 m³

PRODUCTO

Chapa Nogal

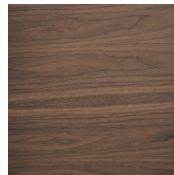

PATAS