

REF. 3.136

MQ2001SF Estantería

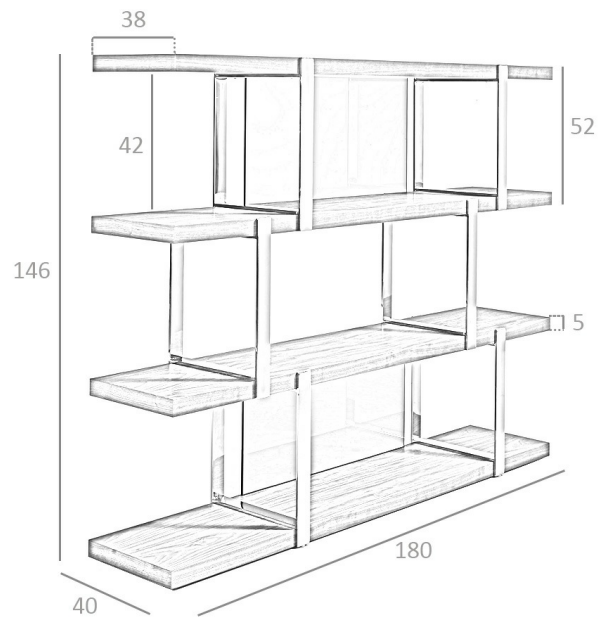

MEDIDAS

Medidas: 180 x 40 x 146 cm.

Peso: 66 Kg.

EMBALAJE

48 x 28 x 187 cm. / 50 Kg.

51 x 9 x 89 cm. / 20 Kg.

VOLUMEN

0,44 m3

PRODUCTO

Chapa Nogal / Acero Cromado

Cristal Ahumado Negro - TTE

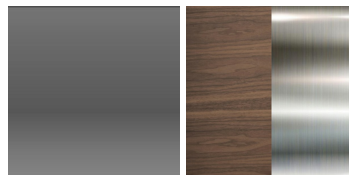

PATAS

Base: Chapa Nogal

