

REF. 3.208

GOB-N5454-3 Consola

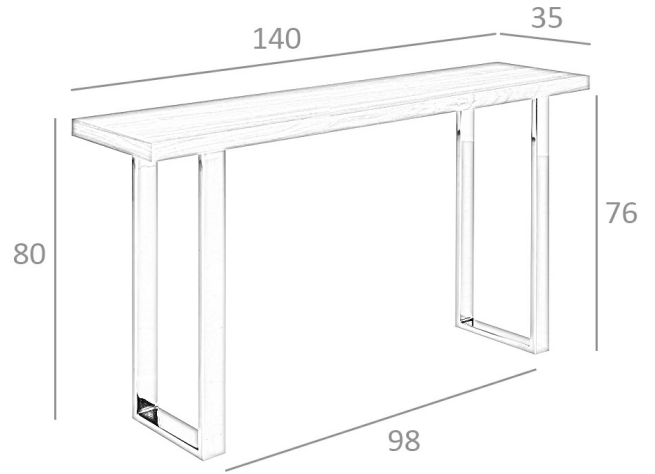

MEDIDAS

Medidas: 140 x 35 x 80 cm.

Peso: 20 Kg.

EMBALAJE

37 x 25 x 142 cm. / 22 Kg.

VOLUMEN

0,39 m³

PRODUCTO

Tapa: Chapa Nogal

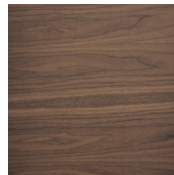

PATAS

Material Patas: Acero Cromado

