

REF. 3.215

MC1802DR Cómoda

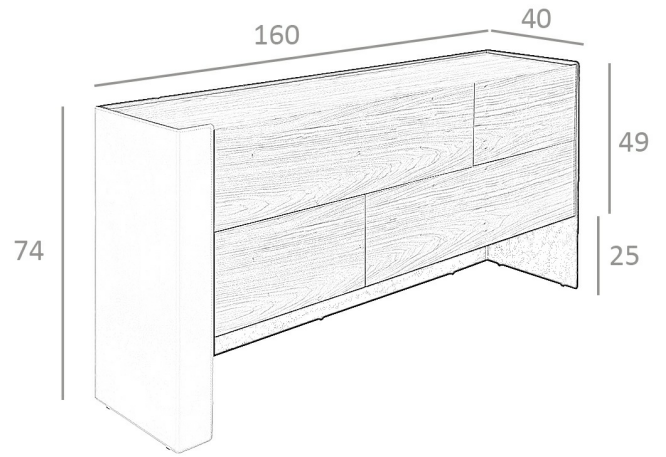

MEDIDAS

Medidas: 160 x 40 x 74 cm.

Peso: 78 Kg.

EMBALAJE

165 x 45 x 80 cm. / 80 Kg.

VOLUMEN

0,77 m³

PRODUCTO

Chapa Nogal - Similar Acua 07

Polipiel

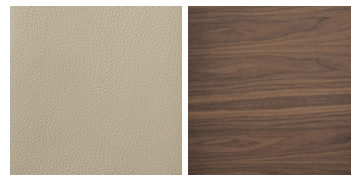

PATAS

Material Patas: Chapa Nogal

