

**REF. 4.115**

**DC-S197A Silla**

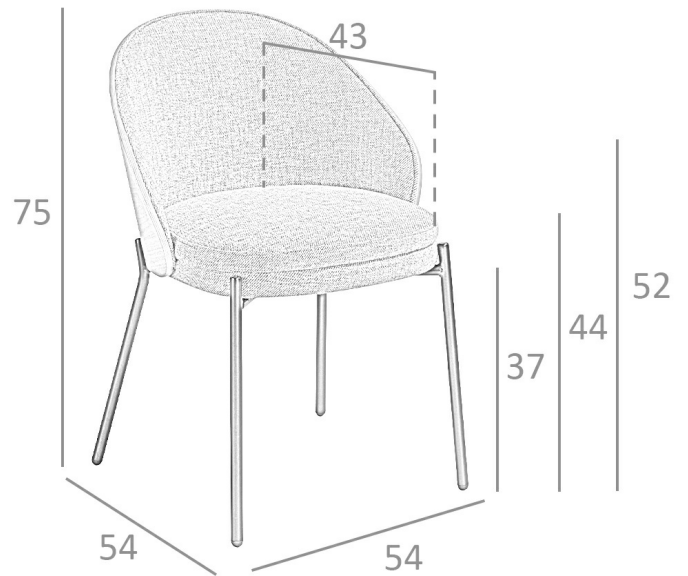

**MEDIDAS**

Medidas: 54 x 54 x 75 cm.

Peso: 6 Kg.

**EMBALAJE**

59 x 54 x 45 cm. / 8 Kg.

**VOLUMEN**

0,14 m3

**PRODUCTO**

Tela - STOCK - TS-SW.Gris02

Chapa Nogal



**PATAS**

Material Patas: Acero color Negro

