

REF. 7.115

MB1502 Mesita de noche

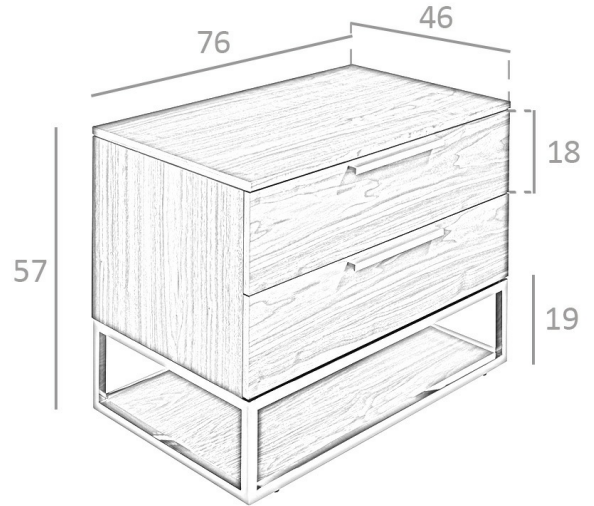

MEDIDAS

Medidas: 76 x 46 x 57 cm.

Peso: 28 Kg.

EMBALAJE

88 x 56 x 67 cm. / 30 Kg.

VOLUMEN

0,29 m3

PRODUCTO

Chapa Nogal

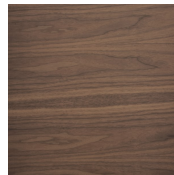

PATAS

Material Patas: Acero Cromado

